



Fonderie Sime S.p.A. - Via Garbo, 27 - 37045 Legnago (VR) - www.sime.it
Tribunale Verona 13531 - R.E.A. VR 171357 - C.C.P. 19423375 - N° Mecc. VR 014435
Capitale Sociale Euro 5.521.200 int. versato - Codice Fiscale/Partita IVA n. IT 01275930236

Comfort Ambiente - Via Garbo, 27 - 37045 Legnago (VR)

Tel +39 0442 631111 - Fax Servizio Commerciale: Italia +39 0442 631291 - Estero +39 0442 631293

Fax Servizio Tecnico +39 0442 631292 - Fax Ufficio Acquisti +39 0442 631292 - Fax Amministrazione +39 0442 631336

8111202 CALD.MUR.MET.MUR.HE 50 R ErP

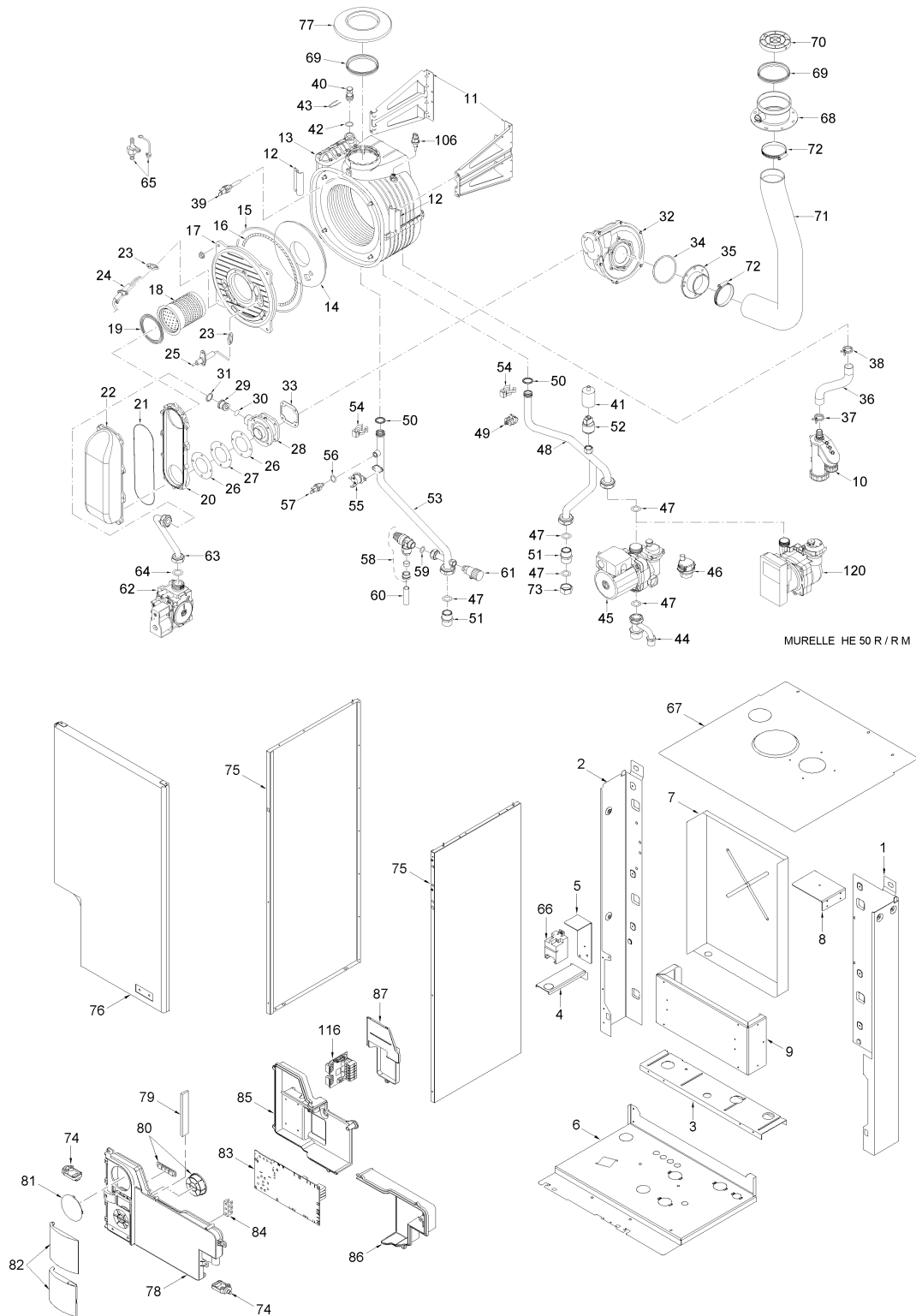

Kit compensatore idraulico / sicurezza ISPSEL (Italia)
Murelle HE 50 R / R M

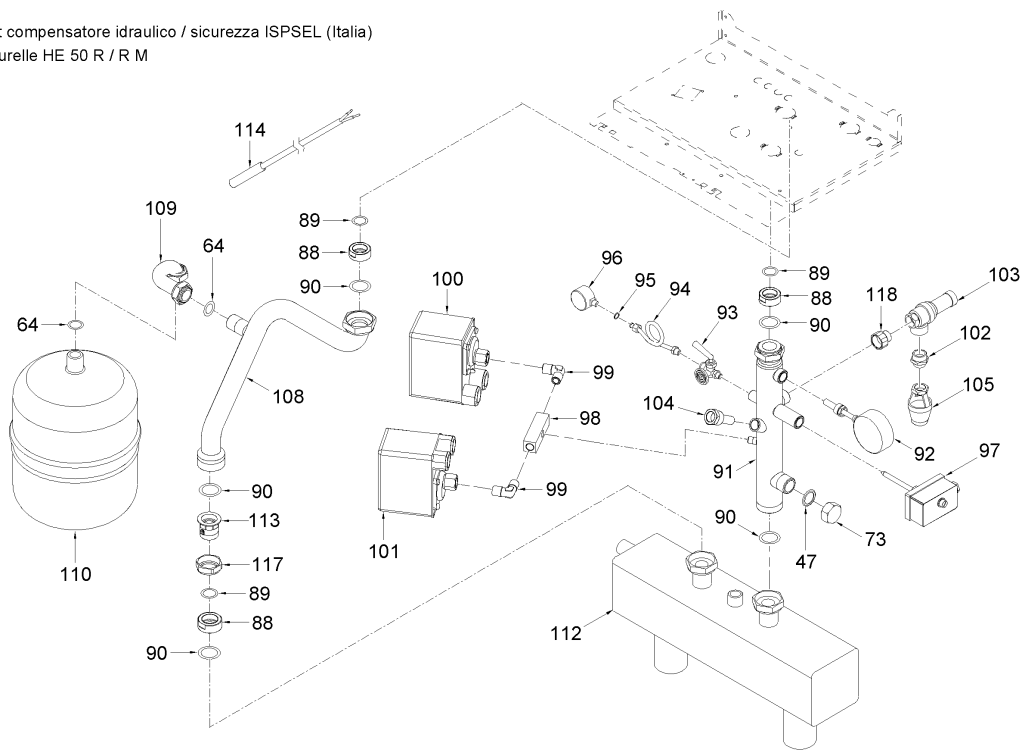

UK - Hydraulic compensator kit (Export)
FR - Kit compensateur hydraulique (Etranger)
ES - Kit compensador hidráulico (Extranjero)
Murelle HE 50 R / R M

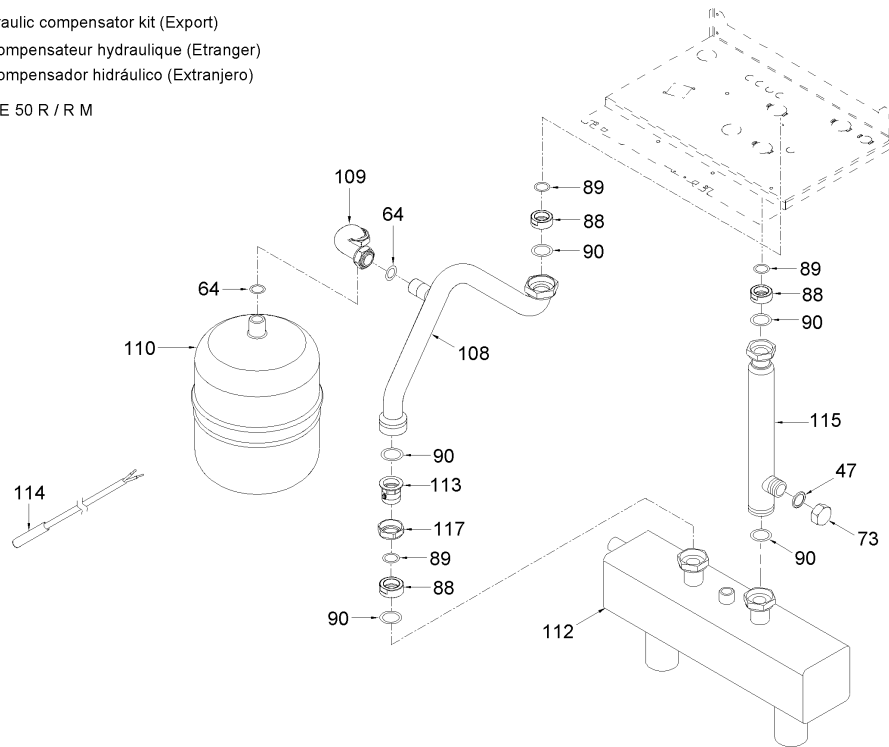

Posiz.	Codice	Descrizione
001	6138533	Right hand side frame part
002	6138632	Left hand side frame part
003	6255431	Expansion vessel lower support
004	6010864	Water trap bracket
005	6256750	Transformer fixing bracket
006	6138897	Frame assembly lower side
007	6266081	Rear panel
008	6256751	Upper protection fixing bracket
009	6267131	Main exchanger supporting brack
010	6277207	Water trap
011	6010860	Main exchanger supporting brack
012	6010829	Main exchanger fixing bracket
013	6278917	Main exchanger body
014	6269011	Main exchanger door insulation
015	6248861	Combustion chamber O-ring
016	6248860	Glass fibre sealing cord

017	6278857	Main exchanger door	
018	6278361	Burner	
019	6174823	Gasket for burner flange	
020	6278891	Side low air-gas hose	
021	6174819	Air-gas hose gasket	
022	6278890	Air-gas hose cover	
023	6174809	Gasket for ignition electrode	
024	6221632	Ignition electrode	
025	6221623	Ionisation electrode	
026	6174812	Mixer/hose gasket	
027	6239206	Mixer closing plate	
028	6274307	Air/gas mixer	
029	6274122	Main burner nozzle 750	MET
029A	6274131	Burner nozzle ø 5,50	GPL
030	6226414	O-ring 117 Ø 13,1x2,62	
031	2030228	Gasket Ø 17x24x2	
032	6261405	Fan	
033	6174816	Gasket for fan flange	
034	6226410	O-Ring Ø 63 x 3	
035	6083055	Duct flange 60	
036	6034155	Condensate drainage pipe	
037	2051122	Clamp diam. 22,1	
038	2051123	Clamp diam. 24,2	
039	6277130	Probe NTC D.4X40	
040	6147412	Plug for air vent connection	
041	6175401	Cover for micro switches	
042	6226464	O-ring 115 diam. 11,91x2,62	
043	6226624	Spring air vent knob	
044	6277943	Pipe conn. C.H. flow - pump	
046	6013182	Automatic air vent	
047	2030257	Gasket diam. 30x22x3	
048	6277944	Pipe connecting pump-exchanger	
049	6231360	Temperature sensor	
050	6226412	O-ring 3068	
051	6120540	Nipple 1"x1" OT	
052	6273603	Water press.transd. HUBA CONTR	
053	6227438	Flowing pipe to C.H. system	
054	6226619	Spring for heat exchanger conne	
055	6146701	100°C safety stat	
056	6022010	Sensor gasket	
057	6231351	Plunged sensor	
058	6040206	Pressure relief valve 1/2" 4 ba	
059	2030255	Gasket Ø 12,5x18,5x3	
060	6157623	Pressure relief valve drain pip	
061	6017211	Manual air vent 1/4"	
062	6243837	Gas valve	
063	6277425	Pipe connecting gas valve-mixer	
064	2030249	Gasket Ø 24x17x3	
065	6280590	Three way fitting + cap kit	
066	6098315	Ignition transformer	
067	6010863	Upper protection	
068	6083061	Flue inlet flange Ø 80	
069	6248802	Gasket Ø 80	
070	6190001	Intake terminal Ø 80	
071	6001152	Air intake pipe 60	
072	2051200	Hose clamp Ø 50-70	
073	6229502	Plug 1" F. OT	
074	6302000	Plastic pin	
075	6304461	casing left/right side panel	
076	6304231	Casing front panel	
077	6230402	External ring for pipe diam.80	
078	6304700	Control panel	
079	6305160	Guidelight with led	
080	6305120	Kit Rubber button	
081	6247327	Cap for time programmer	
082	6304890	Flap door assembly	
083	6301480	Main PCB	
084	2211610	Earth faston	
085	6305000	Cover	
086	6305010	connection cover	
087	6305020	Time programmer cover	
088	6120522	Reducer 1"1/2 x 1"	
089	2030222	Piracriten gasket 23x33x3	
090	2030206	Piracriten gasket Ø 33,5x45x2	
091	6291966	ISPESL safeties pipe	
092	6146004	Thermometer 0-120°C	
093	6216606	Manometer cock ISPESL 1/4"	

094	6216650	Manometer cock connection pipe
095	2030225	Gasket Ø 5,5x11x2
096	6217050	Manometer 0/6 bar
097	6001409	H.L. stat 100°C
098	6291981	Water pressure switch block
099	6291982	90° MM G 1/4" curve
100	6037551	Min.m.reset water press.switch
101	6037550	Safety m.reset water pres.switc
102	6120502	Nipple 3/4"x3/4" OT
103	6042207	Security valve 1/2"X3/4"
104	5064600	Bulb holder 1/2" L=50
105	6269402	Tundish
108	6227439	C.H. return pipe
109	6227680	Pipe connecting D.H.W. expans.
110	6245108	D.H.W. expansion vessel l. 8
112	6216312	Hydraulic compensator
113	6238301	Check valve 1" ART. 4001 DN
114	6231331	D.H.W. tank sensor
115	6291967	C.H. flow pipe
116	6301465	PCB expansion
117	2040302	Brass nut 1-1/2"
118	6120544	Spigot reducer 1/2".x 3/4" F.
120	6272326	Modulating circulating pump
702	6127214	Main cable L=1500
703	6186587	Ionisation electrode cable
704	6319163	3 pole cable connector
705	6319162	4 pole cable connector
706	6319161	5 pole cable connector
707	6319164	9 pole cable connector
708	6319160	14 pole cable connector
709	6299991	4 pole cable connector CN12
710	6316202	Connector 4 poli
711	6316203	Connector 4 poli CN4
712	6316204	Connector 8 poli CN7
713	6319165	5 pole cable connector
714	5197119	Control panel x modul.circul.pu
715	6319147	Modul.pump 3 pole female connec
716	6316200	Connector 2 poli
717	6316201	Connector 4 poli
718	5185150	LPG conversion kit
719	6281545	Replacement rear insulat. kit